

Johnson Noise Thermometry for Harsh Environments

R. Kisner¹, C. L. Britton^{1,2}, U. Jagadish¹, J. B. Wilgen¹, M. Roberts², T. V. Blalock^{2,3}, D. Holcomb¹,
M. Bobrek^{1,2}, M. N. Ericson^{1,2}

¹Oak Ridge National Laboratory, MS6006, Oak Ridge, TN 37831-6006, BRITTONCL@ornl.gov

²Dept. of Electrical and Computer Engineering, The University of Tennessee, Knoxville TN

³Deceased

Abstract—The technology of temperature measurement appears to some to be a mature field. However, to many, requirements for improved performance and reliability are a driver for continual scientific and technology advancement. Although Johnson noise has been proposed as a thermometry method for several decades, it is only recently that digital and analog electronics have made it possible to economically fabricate measurement systems based on Johnson noise. Johnson noise, which is a result of fundamental physics, is caused by the random thermal motions of electrons in all conductors. Its fundamental nature allows us to construct temperature measurement systems that do not require periodic calibration. Thus long, unattended operating intervals are feasible. Several unique implementations of Johnson noise thermometry (JNT) are possible. One permits temperature measurement without contacting the measured surface — inductive JNT. Another implementation measures the Johnson noise of a resistance element in contact with the measured surface — conductive JNT. The resistive element in conductive JNT can be an RTD. Apparatus have been recently fabricated demonstrating the practicality of both JNT implementations. A demonstration of conductive JNT is planned at a nuclear facility within two years. We will present new hardware implementations that allow real-time calibration of the signals that have the potential of allowing a fully-integrated, physically small and robust system to be achieved.

thermocouples are known to exhibit large drifts in high neutron fluxes [1]. The SP-100 temperature measurement system had a 1% measurement uncertainty requirement at 1375 K, an 8 second response time limit, and a requirement for 7 years of unattended operation. No conventional thermometer could meet these goals. However, Johnson noise thermometers had been developed by the Oak Ridge National Laboratory (ORNL), originally for fuel centerline measurement, and were believed to be able to meet these stringent requirements. Johnson noise is a first-principles representation of temperature. Fundamentally, temperature is merely a convenient representation of the mean kinetic energy of an atomic ensemble. Since Johnson noise is a fundamental representation of temperature rather than a response to temperature such as electrical resistance or thermoelectric potential, Johnson noise is immune from chemical and mechanical changes in the material properties of the sensor. Johnson noise thermometry has been applied to in-core temperature. An overview of the application of Johnson noise thermometry to space power reactors was made by Roberts, Blalock, and Shepard in 1989 [2].

Signal Processing Electronics

The Nyquist equation describes the voltage produced by the vibration of the electrons within a resistor at a given temperature. For frequencies below a few gigahertz, Equation 1 shows the relationship between the absolute temperature of a resistor (T), its resistance (R), the frequency band of measurement Δf , and the measured mean-square noise voltage.

$$\overline{V^2} = 4k_B TR\Delta f \quad (1)$$

where k_B represents Boltzmann's constant (1.38×10^{-23} joules/Kelvin).

A direct measurement of the Johnson noise for temperature measurement has several challenges. First, the amplifier gain needs to be both known and stable. Second the amplifier passband and filtering effects of connection cabling must be well known to within the required measurement accuracy. Finally, the resistance of the sensor must be independently and accurately measured. To avoid these difficulties, early Johnson noise thermometers performed a ratio of two noise voltage measurements, one with a resistor at the measurement temperature and the other at a known temperature, switched onto a single amplifier channel. However, changing the connection of the sensor to

TABLE OF CONTENTS

1. INTRODUCTION	1
2. I-NERI JNT IMPLEMENTATION	3
3. INDUCTIVE JOHNSON NOISE THERMOMETRY	5
4. CONCLUSION	7
REFERENCES	8

1. INTRODUCTION

The SP-100 space reactor was designed to have a diverse set of temperature measurements. The primary W/W-Re

the high-gain measurement circuit introduced noise and decreased reliability [3].

The approach that ORNL staff took to minimize these difficulties in the SP-100 thermometry project was to follow the work of Pepper and Brown [4] in which a resistive sensor is connected in series with an inductor and a capacitor forming a tuned circuit. In this approach the ideal mean squared noise voltage is given by

$$\overline{V^2} = \frac{k_B T}{C} \quad (2)$$

where C is the capacitance of the capacitor. The major advantage of this technique is that, for lossless inductors and capacitors (provided that the measurement bandwidth is greater than the tuned circuit bandpass), the measured voltage output is independent of the sensor resistance and the inductance. No measurement of the sensor resistance is needed. Another advantage of the technique is that for a properly tuned circuit, most of the signal power lies in a relatively small band near the resonant frequency. This allows the amplifier bandwidth to be relatively small and reduces its noise contribution to the measurement uncertainty.

A practical limitation with this approach, however, is loss in the inductors. Real inductors have winding resistances (typically frequency dependent) that dissipate energy. In practice, this limits the overall accuracy obtainable with a tuned-circuit implementation of Johnson noise thermometry.

Another implementation restriction for Johnson noise thermometry in space reactors is the capacitive effect of the cable connecting the sensing resistor to the first stage amplifiers. If the cable has significant capacitance, it will block the high frequency portion of the sensor noise before it reaches the measurement system. This filtering of the upper frequencies reduces the bandwidth of the Johnson noise signal. Under the high temperature and radiation environment of a space reactor, the cable capacitance will change over time. One way of compensating for the cable effect is to periodically measure its input impedance and calculate its transfer function. However, the best technique remains to locate the first-stage amplifier near the sensor.

The signal processing electronics for incorporating the Johnson noise temperature measurement system into the SP-100 reactor were not completed during the ORNL project. A radiation and thermally hardened preamplifier package had not yet been developed by the conclusion of the project. Also a technique for verifying the pass band and gain stability of the amplifier had yet to be demonstrated.

Two additional signal-processing concepts were investigated as part of the ORNL SP-100 thermometry project (further work was done under Electric Power Research Institute (EPRI) sponsorship). In the first of these, the temperature measurement resistor is connected in

parallel to two separate high input impedance amplifiers. The output of these amplifiers is partially correlated since each consists of the sum of a correlated noise voltage and uncorrelated amplifier noise voltage. If two Johnson noise amplifier signals, connected to the same resistance, are combined and time averaged, the correlated part of the noise will persist, but the uncorrelated amplifier noise will approach zero. Figure 1 illustrates the concept of cross-correlation; the measured voltage from one amplifier channel is Fourier transformed and correlated and with that from the other to form a cross power spectral density (CPSD) effectively eliminating the noise contribution from the amplifier electronics.

Johnson noise has a flat (white) spectral energy distribution. The shape of the power spectral density functions displayed in Figure 2 is a result of the combined effects of filtering out both the low and high frequencies from the noise and the frequency dependent gain of the amplifier circuit. The low frequency filtering is applied to eliminate the non-thermal noise generated by mechanical vibrations. These microphonic signals are limited to less than a few tens of kilohertz. The upper frequency filtering is applied both to avoid aliasing higher frequencies into the measurement band as well as to minimize the impact of sensor-to-amplifier cable capacitance induced restriction of high frequency transmission.

The CPSD function has units of volts squared per hertz and expresses the voltage-squared content per unit frequency of the measured voltage signal. Integrating the CPSD function over frequency and averaging the result over time provides the mean-square noise voltage for the Nyquist equation as shown in Fig. 1.

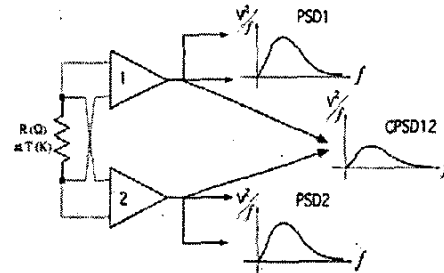

Figure 1. Power Spectral Density Function (PSD) of Each Amplifier Channel Containing Both Correlated and Uncorrelated Noise and the CPSD Function From Both Amplifiers Containing Only Correlated Noise.

Electromagnetic interference spikes and microphonics are two of the biggest problems for a practical implementation of Johnson noise thermometry. In many situations, these effects can completely dominate the noise measurement. This puts a premium on well-implemented grounding, shielding, and filtering. A complementary technique to reduce these effects is to use both knowledge of the spectral energy content of Johnson noise and digital signal processing to recognize and eliminate interferences. Typically narrowband electromagnetic interference appears

as spikes in the long-term average CPSD that can be recognized and removed with only a small reduction in measurement bandwidth as illustrated in Fig. 2.

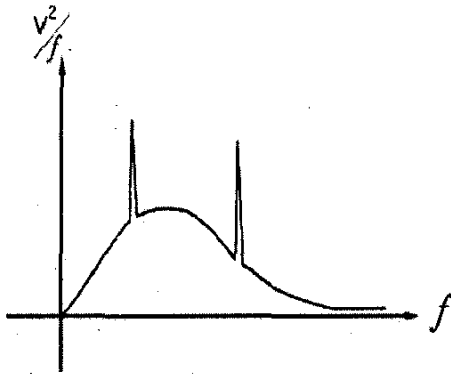

Figure 2. CPSD With Narrowband EMI Spikes.

2. I-NERI JNT IMPLEMENTATION

While the underlying concepts (under NASA sponsorship) and a laboratory prototype (under EPRI sponsorship) of both the cross correlation and digital signal processing had previously been developed by ORNL and the University of Tennessee, the high speed digital signal processing required remained prohibitively expensive in the early 1990s. Consequently, the cross-correlation amplifier electronics were never implemented in an integrated form, and the signal processing software was never finalized.

The current International Nuclear Energy Research Project, led by ORNL on the U.S. side and with the Korean Atomic Energy Research Institute leading the Korean JNT tasks, is focused on implementing a dual mode resistance and Johnson noise thermometer in a rugged, integrated, prototype form. The resistance measurement serves the dual purpose of providing the necessary impedance measurement for the Nyquist equation as well as providing a prompt temperature measurement. Since Johnson noise is a stochastic process, some time is required to perform a measurement. The temperature measurement in the dual mode thermometer is therefore made as a simple resistance measurement whose resistance to temperature conversion is quasi continuously updated using Johnson noise. A schematic illustrating the measurement process is shown as Figure 3.

The CPSD provides the mean-square noise voltage, and the resistance is independently measured, so the remaining variables that have to be known to obtain temperature from the voltage measurements are the amplifier gain as a function of frequency and the effective measurement frequency band (Δf). The technique currently used to obtain the gain-bandwidth product is to initially calibrate the

measurement using a known temperature and treating both properties thereafter as a single constant.

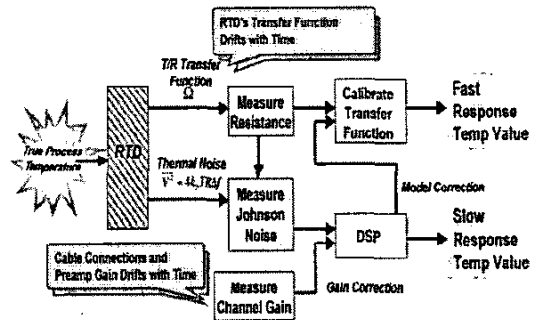

Figure 3. Johnson Noise Thermometry Measurement Process Schematic.

A layout of the system is shown in Fig. 4. High-gain, wide-band Johnson noise preamplifiers with a precision resistance bridge have been implemented in high-density, discrete component electronics. A continuous amplifier gain calibration scheme has also been implemented. The digital signal processing logic has been implemented in LabVIEW™ on a desktop computer and is in the process of being implemented in a field programmable gate array (FPGA) and dedicated digital signal processing (DSP) chip format. The preamplifier head and resistance probe have been packaged in a shielded aluminum enclosure and a coaxial signal interconnection scheme has been implemented. More electronic design details on the implementation will be published as the project completes over the next year.

Electronics Implementation

Figure 5 presents a block diagram of the connectivity of the new system. Each of the two noise channels connects from the preamp/cal head-end box via two sets of coaxial cables arranged in differential pairs. The preamplifier board contains two identical differential-input JFET preamplifiers/filters/gain sections each with a voltage gain of approximately 80dB and a center frequency of approximately 650kHz. Each of the two single-ended signal paths is converted to differential with a high-bandwidth differential amplifier capable of driving 300m of coaxial cable. Each of these cables is terminated in 50 ohms at the receiver box with the shields tied together at the head-end box and isolated. The conductors are also isolated by using capacitive coupling instead of transformer coupling to minimize pickup. The calibration board contains a swept-frequency oscillator that supplies the calibration signal over the noise bandwidth of the amplification chain by sweeping continuously from 50kHz to 2.5MHz and back over an approximate 2 second period and is coupled directly into the front-end preamplifier. A 100μA current is supplied to the input also and a separate differential amplifier measures the voltage drop across the RTD. This voltage is amplified and converted to a 20kHz-90kHz differential pulse stream which

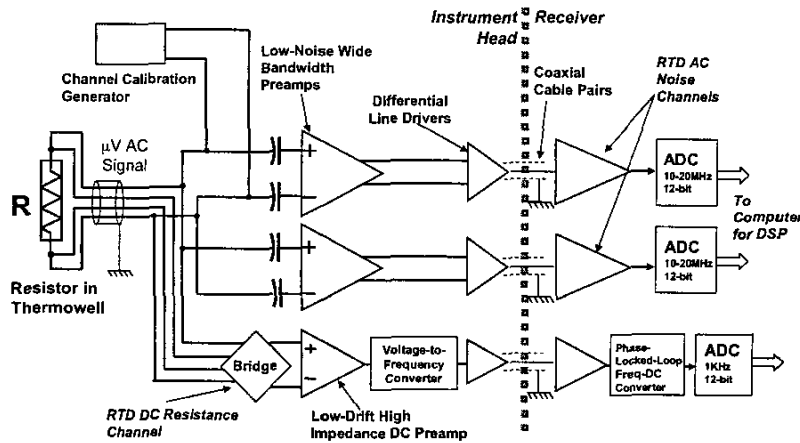

Figure 4. Principal Components And Conceptual Configuration Of The Dual Mode Resistance And Johnson Noise Thermometer Incorporating the Cross-Correlation Technique, Digital Signal Processing, and Channel Gain Calibration.

is then sent to the receiver box which converts it back into a voltage proportional to the value of the resistor. The head-

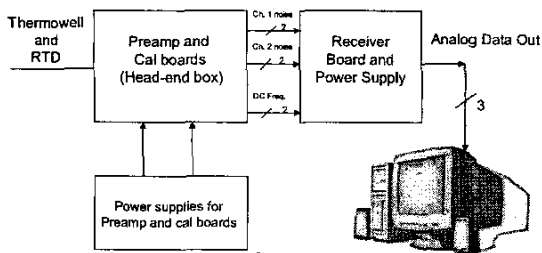

Figure 5. System Block Diagram.

end box has an associated power-supply box which supplies all DC voltages necessary for operation. The preamplifier and cal boards are mounted as a sandwiched pair separated by a sheet steel shield.

The receiver box of the JNT setup shown in Fig. 6 consists of two Johnson noise measurement channels and one DC resistance measurement channel. The signals for the three channels are received differentially by variable gain 250MHz differential-to-single-ended amplifiers. The Johnson noise channels consist of this amplifier followed by a 4-pole Sallen-Key High pass filter with a low-frequency cut-off of approximately 80 KHz. This is then followed by a 4-pole Sallen-Key Low pass filter with a high-frequency cut-off of approximately 2 MHz. The entire channel has a

variable gain of 1 to 10. The DC resistance channel has a front-end differential receiver amplifier similar to the Johnson noise channel. The signal then passes through a 2-pole Sallen-Key high pass filter that has a low-frequency cutoff frequency of approximately 15 KHz. The filtered signal is discriminated to get a rail-to-rail equivalent frequency signal which is then passed into a phase locked loop used as a frequency-to-voltage converter. The resulting output voltage is proportional to the dc equivalent of the resistance measured at the transmitter front end. The single-ended signals out of these three channels are then sent to a computer based DSP using a 4 channel 20 M sample/second ADC board.

Data

Test runs of the system using calibrated metal-film resistors at room temperature in place of the RTD have been performed and the data is shown below. The system has been tested at room temperature with the chosen RTD and works equally well. These tests represent an end-to-end test using the entire system and the actual software algorithm. In the coming months, collaborators at Ohio State University will perform a full system calibration. Figure 7 is a plot of the power spectral densities of each of the two noise channels versus resistance. Also included is the cross-power spectral density of the two channels. Figure 8 is the voltage of the simultaneous DC readout plotted against the same resistance.

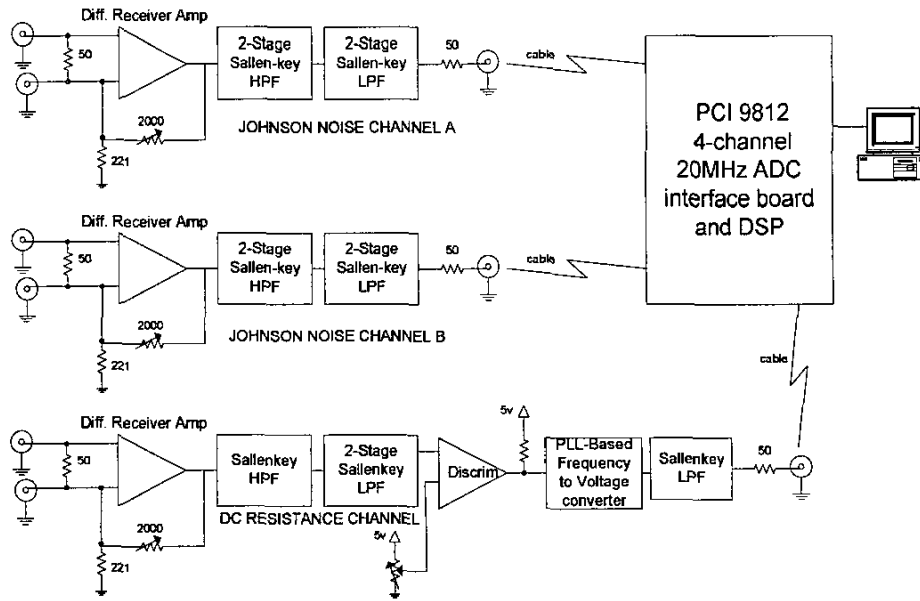

Figure 6. Block Diagram of the Receiver section.

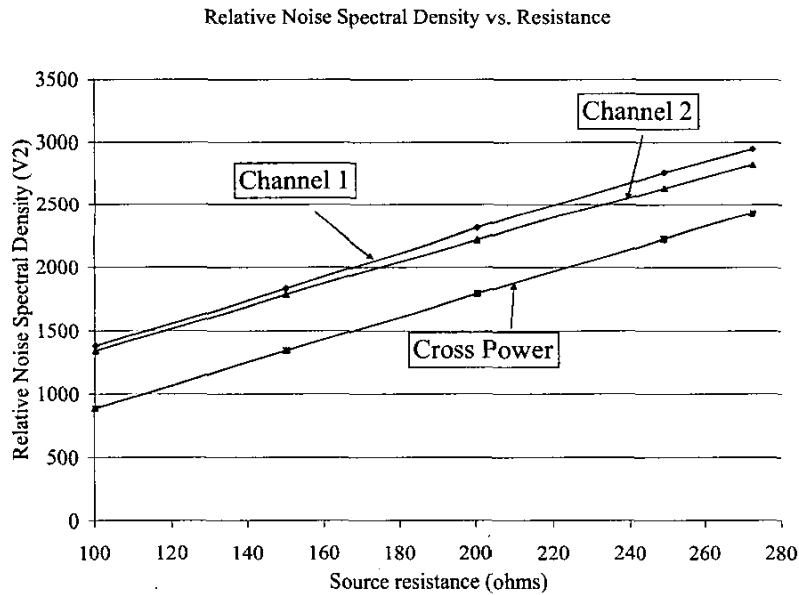

Figure 7. Individual spectral density for each channel and CPSD for both channels versus resistance.

3. INDUCTIVE JOHNSON NOISE THERMOMETRY

Theory

A noise analysis technique based on an inductively coupled measurement system has been attempted only once

previously for sheet steel by Varpula and Seppae [5, 6]. The cited measurement method needed a complicated preamplifier circuit and hardware signal processing to decode the noise signal in contrast to what can be done now with software processing. Also their antenna's noise contribution was too high for a low resistance material such

as aluminum. In our work, we developed a dual-channel preamplifier of a simpler design that couples with software processing algorithms to perform real-time, cross-power spectral density (CPSD) calculations. The integration of the CPSD data directly yields the surface temperature. The CPSD rejects uncorrelated noise contributions from each of the preamplifiers making preamplification noise very low. We also demonstrated the use of a cryogenically cooled copper and a Litz-wire resonant antenna to reduce the antenna's noise contribution. The Litz-wire antenna is necessary for low resistance materials such as aluminum.

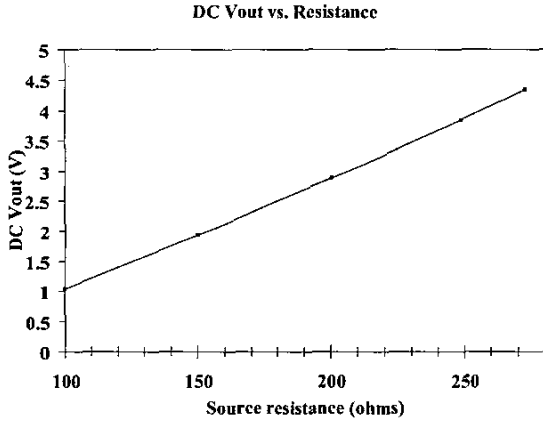

Figure 8. Voltage output versus resistance.

The inductive Johnson noise thermometry principle collects thermal noise magnetically radiated from a surface by a special antenna located nearby. The Johnson noise received in a resonant antenna circuit has the same mathematical relationship as that of the resonant conductive method. For the tuned circuit, the mean-squared voltage across the capacitor becomes independent of R and L although the voltage fluctuations themselves (the actual time-domain behavior) depend on R and L . The dissipation losses (which are the same as R) from the material under measurement and the antenna are mutually coupled as shown in Fig. 9 (i.e., the noise sources add).

To function, the dissipation of the material being measured must dominate those of the resonant circuit. Hence, the induction method can be used to measure the temperature in conductive surfaces. In fact, the surface resistivity can also be measured by an independent calculation of the spectrum broadening (the quality factor or Q). The relationship shown in (2) can be expanded for a resonant antenna and simplifies in the limit to

$$\overline{V^2} = 4k_B TR \frac{\pi f_0}{2 Q} = \frac{K_B T}{C} \quad (3)$$

where V is the measured voltage, K_B is Boltzmann's constant, T is absolute temperature, R is equivalent

resistance, f_0 is the center frequency, Q is the resonance quality factor, and C is the effective parallel capacitance.

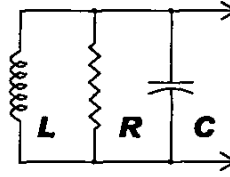

Figure 9. Inductance, L , Capacitance, C , and Resistance, R , of the antenna combine with the metal plate to form a parallel resonant circuit.

The noise voltage becomes proportional to the temperature and the capacitance. Fortunately, the capacitance of the circuit can be dominated by a fixed parallel capacitor and the uncertainty from plate to antenna movement minimized. This is the approach we took in our apparatus.

The temperature measurement uncertainty is a function of measurement statistics. Very broadly, with measurement averaging times between 1 and 10 seconds and bandwidths of 20 to 40 kHz, uncertainty of about one percent of absolute temperature value is expected.

Experimental Apparatus

Our apparatus is contained in an aluminum cylinder, which acts as a Faraday shield as well as a physical support for the internal components. Externally mounted to the cylinder are two preamplifier modules, for which electrical shielding is critical. Inside the cylinder is a cryogenic chamber made of polystyrene that holds the copper coil antenna, an air supply cools the bottom of the antenna chamber. Several layers of low-loss sheet ceramic insulator act as a support and heat shield for the antenna chamber. Below the sheet insulation is the metal plate and heater, which sit in a bed of high temperature insulation. A piston is located below the heated steel plate to vary the distance between the antenna and the steel plate being measured. The apparatus is shown diagrammatically in Fig. 10. Two materials were used for the heated metal plate: aluminum and steel.

Results and Accomplishments

We discovered the FET preamplifiers' extreme propensity toward instability. The tendency to break into oscillations under high- Q conditions plagued us throughout the development. We further discovered that frequency dependent loading by the gate of the FET transistors is one of the chief limiting factors of the frequency at which we can operate. Although we designed a very wide bandwidth preamplifier, the anomalous loading of the gates forced operation down to 1.5 MHz, which coincidentally was the same range as the Varpula and Seppae instrument. We purchased and surveyed many low noise high frequency FET transistors in an attempt to overcome the loading problem. This effect has only been marginally studied by

microcircuit researchers and it is not modeled in SPICE. We believe that further research into this effect would be very beneficial.

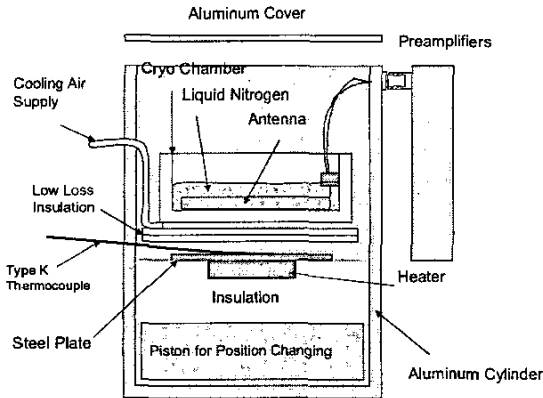

Figure 10. Diagram of Experimental Apparatus Showing Internal Components.

The CPSD is filtered using exponential averaging with a 10-second time constant. Simple integration of the resonance curve gives a value directly proportional to the measured temperature. Temperature as measured by type K thermocouple is plotted against the area under CPSD as derived from a 1.5 MHz resonant antenna consisting of Litz wire cooled to 77K. Temperatures of 77K substantially reduced antenna noise. The results, shown in Fig. 11, are closely correlated as seen by the tight scattering around a linear fit. The data are taken as a steel plate cools from 500°C to to 180°C. Measurement uncertainty of better than +/-2°C was shown. This uncertainty was better than one percent absolute. A typical resonance curve is shown in Fig. 12.

In our experiments we used both copper and Litz wire coil with nine turns in a planar orientation. A typical copper coil is shown in Figure 13. The coil resonates with a high Q tuning capacitor placed directly across it, not shown. Both coil and capacitor are submerged in a liquid nitrogen bath. At 77K, the Q of the circuit more than doubles compared

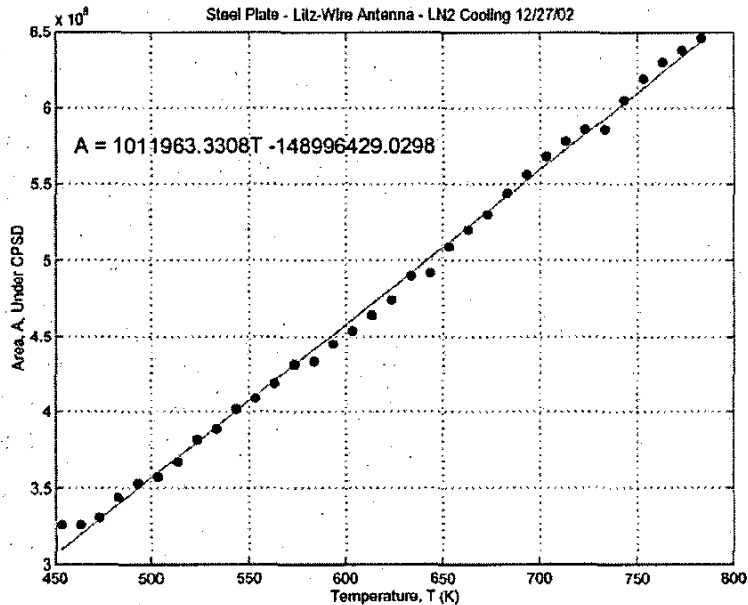

Figure 11. Tracking of Inductive Noise Temperature with Litz Coil Antenna Compared with a Type K Reference Thermocouple.

We determined that all calculations of temperature should be done algorithmically in software. CPSD processing of the two preamplifier signals worked to reduce the effective noise contribution of the preamplifiers to a fraction of their individual noise — an improvement of better than 20dB was observed. The CPSD method is especially useful when the preamplifiers noise varies. Otherwise, a baseline must be established and a calibration made. With the CPSD, no base noise calibration is needed.

with room temperature conditions. The Litz wire is another doubling in Q over the copper.

Because aluminum has five times the electrical conductivity of steel, the resonant noise signal will be lower, which places more demands on the antenna design. Antennas for aluminum applications must use cryogenically cooled Litz wire coil. Loading curves comparing aluminum and steel are shown in Fig. 14. In addition, the bandwidth is reduced with aluminum.

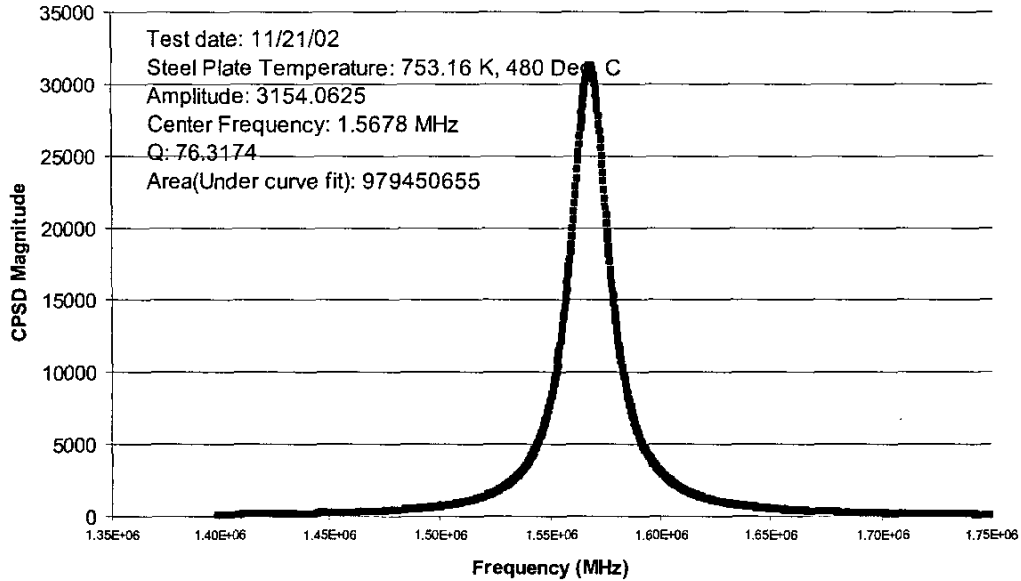

Figure 12. Typical Resonance Curve of the Measured Noise Spectra with Cryogenically Cooled Copper Tubing Coil.

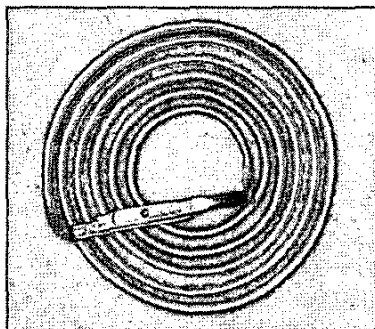

Figure 13. Copper Antenna Coil, shown without tuning capacitor.

We discovered that for temperature measurements of steel plates, given an antenna diameter of seven inches, at a working distance of 1.5 inches, 90 percent of the noise emission originates from the plate. The equivalent temperature of the antenna (and electronics) was approximately 65K

4. CONCLUSION

Johnson noise thermometry is becoming progressively more possible for long-term, high-reliability implementation as signal processing technology progresses and engineering expertise is applied. While Johnson noise thermometry has been demonstrated by a number of groups for nuclear reactor implementations over the past thirty years, one significant engineering hurdle remains to be overcome before the technology can be adopted. A radiation and

thermally hardened version of the preamplifier electronics remains to be developed. Both the radiation and temperature requirements for space reactor implementation will push the state-of-the-art in discrete electronics requiring significant engineering effort. Further, to minimize the system mass, it would be desirable to implement the electronics into a highly integrated, high-radiation-tolerance package using high-temperature electronics (silicon on sapphire or silicon carbide for example).

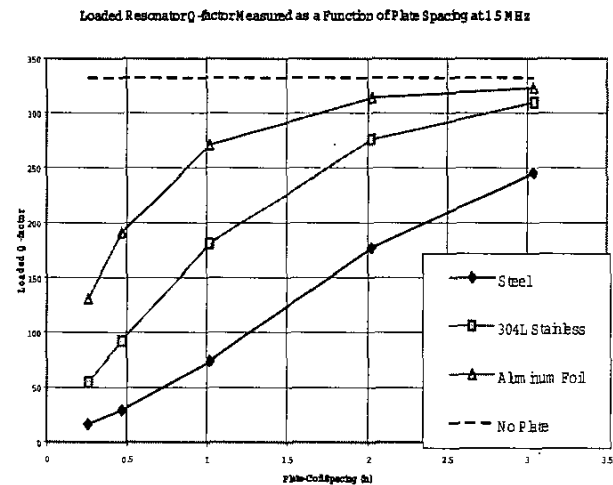

Figure 14. Comparison of Antenna Loading from Steel, Stainless Steel, and Aluminum.

We have not only constructed a system for resistive Johnson noise measurements, but also an apparatus for demonstrating Johnson-noise-based temperature

measurements of heated metal plates. Our apparatus is suitable for testing the performance of a variety of components. We conducted tests with a mild steel plate, which we heated to 500°C and allowed to cool back to room temperature. The data show excellent linearity compared with a type K thermocouple in direct contact with the plate. Experiments were also performed with an aluminum plate.

Significant improvements were demonstrated over the previous work of Varpula and Seppae: (1) improved preamplifier configuration, (2) direct real-time digital signal processing that can be implemented with typical computer components, and (3) cryogenic cooling of the detection antenna.

This work demonstrates that the inductive Johnson noise method works for steel and has great promise for aluminum. Although the design is non-trivial, the technology can be developed into a field instrument for metal mills and other industrial applications.

This research was sponsored by the U.S. Department of Energy and performed at Oak Ridge National Laboratory, managed by UT-Battelle for the U.S. Department of Energy under Contract No. DE-AC05-00OR22725.

REFERENCES

- [1] Brixy, H., Hecker, R., Oehmen, J., Barbonus, P., and Hans, R., "Development Work on Noise Thermometry and Improvement of Conventional Thermocouples for Applications in Nuclear Process Heat," *Specialists' Meeting on Gas Cooled Reactor Core and High Temperature Instrumentation*, Windermere, England, IWGGCR-5, IAEA-TC-389/6-7, International Atomic Energy Agency, Vienna, June 14-17, 1982.
- [2] Roberts, M. J., Blalock, T. V., and Shepard, R. L., "Application of Johnson Noise Thermometry to Space Nuclear Reactors," *Space Nuclear Power Systems*, 10 & 11, The Proceedings of the 6th Symposium on Space Nuclear Power Systems (1989), Krieger Publishing Co., Melbourne, Florida, January 1993, pp. 87-93.
- [3] Garrison, J. B. and Lawson, A. W., "An Absolute Noise Thermometer for High Temperatures and High Pressures," *Review of Scientific Instruments*, 20, 785-94 (1949).
- [4] Pepper, M. G. and Brown, J. B., "Absolute High-Temperature Johnson Noise Thermometry," *J. Phys. E: Sci. Instrum.*, 12, 31-34 (January 1979).
- [5] T. Varpula and H. Seppae, "Inductive Noise Thermometer: Practical Realization," *Rev. Sci. Instrum.* 64 (6), June 1993, pp. 1593.
- [6] H. Seppae and Varpula, "Inductive Noise Thermometer: Theoretical Aspects," *J. Appl. Phys.* 74 (2), July 15, 1993, pp. 771.

BIOGRAPHIES

Roger Kisner has BS/Nuclear Science, MS/Nuclear Engineering, Virginia Tech. degrees and a PE Electrical Engineering, Tennessee. He has developed sensors and controls for nuclear reactor protection systems and digital and analog electronic instruments for industrial applications as well as scientific experiments. His research, development, and design extends over

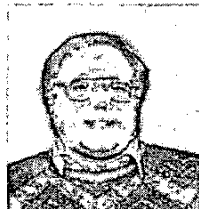

thermometry, advanced sensor technology, quantum optics, laser-based ultrasonics, torsional ultrasonics, linear microphones, actuator-transducers, and acoustic tomography. Other technical areas include electro-optics, high-reliability and fault-tolerant electronics, system packaging, thermal management, and human-system integration. His most recent work has been in developing Johnson noise temperature measurement systems, measurements in ultrahigh magnetic fields, and measurements related to transmission line power conductors. Roger has commercial/industrial experience in addition to his R&D experience at Oak Ridge National Laboratory. He was Vice President of IMPAC products, a manufacturer of electronic controllers and Vice President of Spectrum Medical Technologies, a developer of medical electronic instruments. He has over 40 technical papers and reports, and was a past Section Editor of the *Nuclear Safety Journal*. He has several patents such as "Apparatus and Method for Respiratory Monitoring" (5,309,921 and 5,800,360) and "New Lighting System of Encapsulated Luminous Material" (5,969,472). Several invention disclosures and patents are pending.

Chuck Britton is a member of the Monolithic Systems Development Group in the Engineering Science and Technology Division at ORNL and is an Adjunct Assistant Professor of Electrical and Computer Engineering at the University of Tennessee, Knoxville where he received the B. S., M. S., and Ph.D.



degrees. He worked for Hewlett-Packard Co., E.G. & G., and North American Philips prior to coming to ORNL. He is also presently involved in neutron detector electronics development, electronics for harsh environments, and micro-electro-mechanical systems (MEMS) at ORNL. He has over 70 publications and 11 patents in the field of electronics and integrated circuit design. He has received several awards including the 2001 Award for Excellence in Technology Transfer from the Federal Laboratory Consortium for Technology Transfer. He was Conference Editor and is presently an Associate Editor for the *IEEE Transactions on Nuclear Science*. He is actively involved

with the IEEE as an elected member of the Nuclear and Plasma Sciences Society (NPSS) AdCom.

Usha Jagadish received her Ph.D. in Electrical Engineering from Texas A&M University, College Station, Texas in May 1993. During the course of her study she worked as a Research Associate in the Power System Automation laboratory at Texas A&M. Her focus of study was in the area of space station power automation, using mixed signal CMOS



Application Specific ICs (ASICs). She received both her Bachelors' and Masters' degrees in Electrical Engineering from Anna University, Madras, India, where she also worked as a Teaching and Research fellow and was part of the teaching staff in the Electrical Engineering Department for two years. She joined the Oak Ridge National Laboratory, Oak Ridge, Tennessee, as a Research and Development Staff in the Monolithic Systems Development group in 1994. She has since then, concentrated on the development of highly integrated CMOS analog and mixed signal ASICs for use in high-energy and heavy-ion physics experiments. She has also been working in wireless electronics development by designing and implementing application specific wireless-circuit designs. Her areas of interest include mixed-signal analog and digital circuit design, wireless integrated circuit design, sensor integration, VLSI and wireless system design.

J. B. Wilgen is currently a development engineer in the RF & Microwave Systems Group in the Engineering Science and Technology Division at the Oak Ridge National Laboratory. He has more than 25 years experience in electromagnetics, wave propagation, sensors, and receiver applications, including development of RF & microwave instrumentation



for measuring material properties and monitoring processes. Dr. Wilgen received a Ph. D. in Electrical Engineering from the California Institute of Technology in 1975, a M.S. degree in Electrical Engineering, from Caltech in 1969, and a B.A. degree in Physics and Mathematics from the University of Minnesota, Morris in 1968. He has co-authored over 50 refereed publications and more than 200 additional publications and presentations at national and international conferences and symposia.

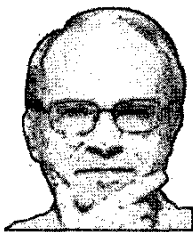

M. J. Roberts is a professor of Electrical and Computer Engineering at the University of Tennessee, Knoxville, TN. He has worked and published in several diverse areas of Electrical Engineering including embedded systems, sensor and instrumentation development, Johnson noise thermometry and spectroscopy

as applied to process control. He has taught at the University of Tennessee full-time since 1984. Courses he has taught include circuit theory, signals and systems, engineering applications of optics and random variables at the undergraduate and graduate levels. He is a senior member of the IEEE.

Dr. T. Vaughn Blalock was a Professor in the Department of Electrical and Computer Engineering of the University of Tennessee for 38 years. At the University, he was a beloved teacher and mentor to countless young engineers and was a dedicated administrator, serving at various times as Associate Department Head and Department Head of Electrical and Computer Engineering. Renown in the



field of analog electronics and instrumentation, he also worked for 40 years at the Oak Ridge National Laboratory and as a consultant to a number of technology firms in the East Tennessee region. Among Dr. Blalock's honors are the Chancellor's Award for Excellence in Teaching, the Eta Kappa Nu EE Outstanding Teaching Award, the M.E. Brooks Distinguished Faculty Award, the Mortar Board Outstanding Faculty Award, the Alumni Outstanding Teacher Award, the IEEE Region 3 Joseph M. Biedenback Outstanding Engineering Educator Award, and the Award of Excellence from the Halliburton Education Foundation. Dr. Blalock published nearly 50 refereed papers and holds 5 patents spanning Johnson noise thermometry, thermal noise power thermometry, double delay-line filters for pulse amplifiers, and a high level white noise generator. He was also presented an Industrial Research-100 Award for the development of the Johnson Noise Power Thermometer-Industrial Prototype System.

David E. Holcomb is currently a senior research staff member of the Nuclear Science and Technology Division of the Oak Ridge National Laboratory. He received a B.S. in engineering science from Colorado State University in 1987, a masters degree in nuclear engineering from The Ohio State University in



1990 and his Ph.D. degree from The Ohio State University in nuclear engineering in 1992. Dr. Holcomb is currently U.S. principal investigator for an I-NERI Project with Republic of Korea on Development Of Enhanced Reactor Operation Strategy Through Improved Sensing And Control At Nuclear Power Plants. He is also principal investigator on the NERI project Miniature, Scintillation-Based, In-Core, Self-Powered Flux and Temperature Probe for HTGRs. His additional responsibilities include being principal investigator on a solid-state neutron detector development project for DOE-NNSA as well as serving as a reactor plant technical advisor to DOE on the GT-MHR plutonium disposition reactor. Dr. Holcomb also serves as

the instrumentation specialist on the High Flux Isotope Reactor experimental review committee. Dr. Holcomb is the reactor instrumentation representative for the ORNL Jupiter Icy Moons Orbiter project team.

Miljko Bobrek received his B.S. and M.S. in Electrical Engineering from the University of Banja Luka in former Yugoslavia in 1976 and 1982 respectively. From 1976 to 1989 he was employed at "Rudi Cajavec", Consumer Electronics Company in Banja Luka. In 1989, he joined The University of Banja Luka as a research and teaching assistant, and spent there three years. He entered his Ph.D. program at the University of Tennessee,



Department of Electrical Engineering in January 1993, and graduated with the degree of Doctor of Philosophy in August 1996. After spending a year at the University of Tennessee as a Research Assistant Professor, he joined the Monolithic Systems Research Group at the Oak Ridge National Laboratory (ORNL). Since 1994, he has been teaching undergraduate and graduate courses in electrical engineering at the University of Tennessee. His research interests include development and implementation of advanced methods in signal processing and digital communications. He published as an author and co-author in several signal processing and VLSI design journals. Miljko Bobrek is a member of the IEEE and a member of the Phi Kappa Phi societies.

Nance Ericson is a member of the Monolithic Systems Development Group in the Engineering Science and Technology Division at the Oak Ridge National Laboratory. He also serves as an Adjunct Assistant Professor of Electrical Engineering at the University of Tennessee, Knoxville. He received the B.Sc. degree from Christian Brothers University,



Memphis, TN in 1987, the M.S. degree from the University of Tennessee, Knoxville in 1993, and the Ph.D. from the University of Tennessee, Knoxville in 2002, all in electrical engineering. Presently, he is involved in a variety of research projects with focus on the design of mixed-signal CMOS integrated circuits and integrated sensors for harsh environment and biomedical applications. His research interests include physiological/biological sensing, nanostructures, high-resolution data converters in SOS-CMOS, and high-temperature integrated circuits. He has authored or coauthored over 60 technical publications. He holds seven patents in the area of high-temperature measurement, integrated photo-spectrometers, and implantable sensing methods.